

DOI: 10.5281/zenodo.3249184

CZU 621.313.333-192



UNIVERSAL PROTECTION DEVICE AS AN EFFICIENT WAY TO INCREASE THE OPERATIONAL RELIABILITY OF ASYNCHRONOUS ENGINES

Veaceslav Shapovalov*

*State Agrarian University of Moldova, 44, Mircesht str., Chisinau, Republic of Moldova**Corresponding author: Veaceslav Shapovalov, email: Veaceslav.Shapovalov@uniflux-line.ne,
<https://orcid.org/0000-0002-9491-6559>

Received: May, 02, 2019

Accepted: June, 14, 2019

Abstract. The paper presents the relevant topic of improving protection devices for asynchronous engines used in agriculture. We have also provided the data of technical and technological damage. There have been identified the main causes of asynchronous motor failure. You may also find a short list of the main existing protection systems for induction motors, the analysis of their shortcomings and prospects for further improvement. We have justified the structural scheme of a universal protective device, which consists of the following channels: a current overload control channel, a rotor seizure channel and a feed line phase failure monitoring channel. We have also given a circuit scheme of the proposed protective device and the description of the circuit operation in the operational mode as well as in various emergency modes. The use of a microcircuit-comparator of the type K554 CA3 (the operational amplifier) as a threshold element with an adjustable threshold voltage value is considered to be an original technical solution.

Keywords: *asynchronous motor accident rate, asynchronous motor protection.*

I. Introduction

Three-phase short-circuited asynchronous motors of the latest series are considered the most reliable electric machines. However, there is a relatively high percentage of their failure in agriculture. As a result, agriculture of the Republic of Moldova suffers large losses from the electrical equipment that fails to operate. For example, if an electric motor of low or medium power fails to work their owners have to pay about 700-1200 lei. Technological losses due to the failure of electric motors significantly exceed their price. For instance, the failure of at least one of the elements of electrical equipment in the production milking and primary milk processing lines at a farm for 200 heads leads to production damage, estimated at almost 7000 lei, which is much higher than the cost of the failed device.

A similar situation may be found at CIS livestock farms. Studies conducted at the All-Union Institute on Electrification of Agriculture (AVIESH) showed that the damage from one electric motor in Russian agriculture of Russia is approximately 2500-3500 rubles.

Having analyzed the research results, we can conclude [1] that about 15-19% of all electric engines installed in households are repaired annually in Moldova. The studies conducted in other countries with developed animal husbandry (Estonia, Latvia, Ukraine and

the USA) [2], have found out that up to 12.5-15.0% of all electric motors were repaired in some months of the year, which is significantly more than the number of new electric engines, purchased by households.

As numerous studies have shown, one of the main reasons is insufficient reliability protection of electric motors from emergency modes. The consequence of this situation is the low operational reliability of electric motors in agriculture - on average their service life does not exceed 4.0-5.0 years, only 3.0-4.0 years in animal husbandry with a total operating time of 1500-2500 hours.

Thus, every year a huge number of failed electric motors should be repaired in agriculture, which requires many scarce materials, electricity and expensive working time. Therefore, the problem of improving operational reliability of electric engines in agriculture should be solved by improving their protection, as it is the problem of great national economic importance.

II. Materials and methods

Currently, both in the Republic of Moldova and abroad [3, 4] the main protection means of induction motors is various thermal relays with bimetallic elements. It is well-known that these thermal relays have a number of disadvantages.

First, these devices function indirectly, they react to the temperature of the thermal relay, and not to the amount of current in phases, that is, they indirectly model the heating process. Meanwhile, heating processes of the engine and the thermal relay differ significantly, and a large current does not always mean a high winding temperature [5].

Secondly, the thermal relay has a wide range of characteristics. As a result, they do not often work in case of overloads within 20-50% of the nominal power. S. Valobueva, Yu. Zaitseva and A. Musin [6,7,8,9] showed that only 67% of thermal relays shut off the electric motor at load currents 20% higher than the nominal, and only 21% of thermal relays protect electric motors from the phase failure.

Thirdly, according to S. Kostruby [10] in the conditions of livestock farms, when a touch voltage or a step voltage of more than 24V appears, the protection device should react within $5 \cdot 10$ seconds. This condition is ignored by non-thermal relays of the TRN type, three-pole thermal relays with improved characteristics and accelerated operation in the case of a non-full-phase mode such as PTT and TRL. Moreover, thermal relays require special adjustment both before installation and during operation.

In the Republic of Moldova and abroad the same protection is used against emergency overloads of the UBTP type (universal built-in temperature protection [11,12,13]. It reacts depending on the temperature of the motor winding. The introduction of UBTP made it possible to reduce the level of accidents of electric motors during overloads. However, a number of shortcomings due to the protection design itself did not allow it to be massively introduced into practice. The main shortcoming is thermal inertia of posistors [9]. There are some other disadvantages of the UVTZ mentioned in the technical literature, such as: low sensitivity to short-circuit currents and the difficulty of mounting measuring transducers (especially when electric motors are being repaired).

Phase failure of the supply line is often met in agriculture. This is due to an insufficiently high reliability level of agricultural power supply. The specified abnormal conditions may also occur in case of the burnout of one or several fuse-links in the power distribution device.

Thermal overload protection schemes considered above [14,15] also ensure protection against work on two phases. However, the reliability of thermal protection actuation depends on the amount of overload on the motor shaft and is insufficient when electric motors are loaded less than 50% of the nominal power.

At the Department of Electrical Engineering of the Latvian Agricultural Academy there was developed a motor protection device of the PhSP type (phase-sensitive protection devices [16]. under the guidance of Professor A. Grundulis. This device is designed to protect against phase failure and controls the phase angle between load currents, varying with a value of 120° in the symmetrical mode up to 180° (or 0°) in case of phase failure. The device has been widely used in agriculture in Latvia. However, despite the relative simplicity of the scheme and the ease of operation, the device has a number of drawbacks:

1. The device sometimes starts working because inrush currents.
2. The device is insensitive to small technological overload (up to 50%).
3. The device does not respond to the overload duration and is triggered instantly.
4. The device weighs a lot and is voluminous.
5. A separate unit is designed for a small range of engine power. Therefore, it is necessary to have several dimensions of the protective device.

These drawbacks were partially eliminated in further modifications of the PhSP-U and PhSP-M devices.

The studies conducted at a number of livestock farms of the Republic of Moldova [1], as well as the analysis of the results of similar studies carried out in some other countries with developed animal husbandry, allow us to draw some conclusions:

- ❖ Only a limited number of three-phase asynchronous motors is massively used in animal husbandry in the Republic of Moldova. These are electric motors of the AO2 and 4A series, both of general industrial and special performance, of low and medium power (0.18 kW – 11.0 kW).

- ❖ It has been established that about 70% of failures of asynchronous engines operating in agricultural production make up such emergency modes as overload, rotor seizures and phase failure of the supply line.

- ❖ Current protection schemes for electric motors against overload and phase failure are ineffective due to a number of inherent shortcomings.

- ❖ About 70-80% of all failures in the operation of low-voltage asynchronous electric motors can be prevented by using reliable protection and 30-20% - by improving the quality of service.

Therefore, nowadays the development and implementation of simple reliable and highly effective protection is the only way to significantly reduce the accident percentage of electric motors used in agricultural production [17,18,19,20]. At the same time, protection devices that are being developed should be oriented to asynchronous three-phase engines of mass use, i.e. with a capacity from 0.18 kW to 11.0 kW and be universal (protect the engine from overload, phase failure and rotor seizures).

III. Results and discussions

The proposed protection device is universal and protects the motor from the most common emergency conditions, such as overload, rotor seizures and phase failure. Thus, the block diagram of the device contains a number of necessary structural blocks. They are the following:

- Primary converters (alarm sensors).
- Threshold elements (which are necessary to detune from possible signals of current sensors that are not emergency).
- Elements of time delay (which are necessary to detune from inrush currents and small or short-term overloads).
- Elements to compare signals from primary converters and reference signals to obtain a logical conclusion that the signal is an alarm.
- Power supply electronic elements of the protection circuit.
- The actuator for switching the power circuit of the motor.

Figure 1 shows the structural scheme of the given protection device, which consists of these structural elements. The structural scheme consists of two channels: a current overload control channel and a phase failure control channel [21,22]. The current overload control channel of the motor consists of a current sensor (CS), the first threshold element (THR1), the time delay element (TD), the second threshold element (THR2) and the actuator of the power circuit (KM).

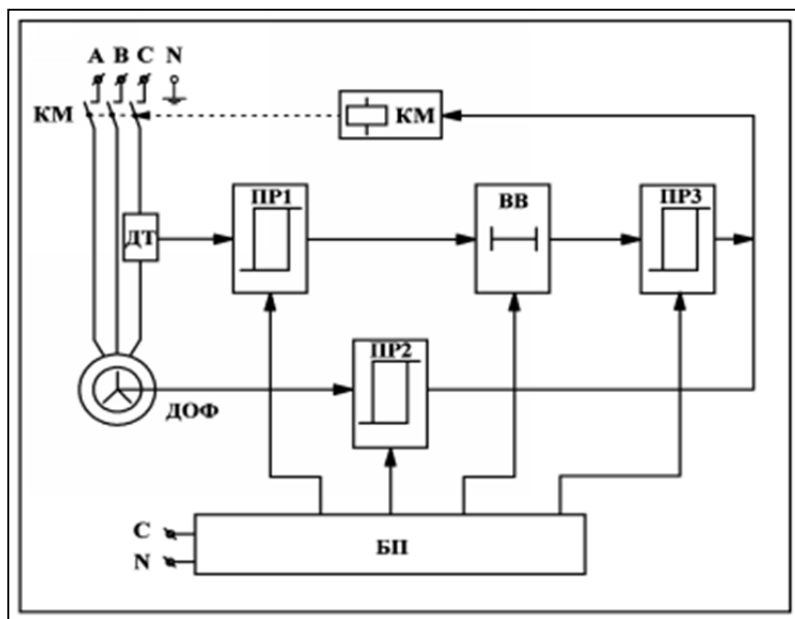

Figure 1. The block scheme of the protection device.

The phase failure control channel includes: a phase failure sensor (PhFS), a threshold element (ThR2) and a power circuit actuator (KM). The power supply of electronic circuit elements is common for both channels.

Functioning of the scheme in the current overload control mode.

Motor overload is monitored by the primary current converter. The reconstructed current sensor from the station of the submersible pump control 5801-0362Г-Y2 is used as the primary converter. The primary converter is successively connected to the stator phase circuit of the motor and provides the output voltage, the value of which is directly proportional to the load current of the motor. CS voltage is transmitted to the rectifier element and further to the threshold element THR1. When a voltage on one of the THR1 elements is greater than or equal to the specified (reference voltage), THR1 opens and passes the signal to the time delay element TD. The TD element provides a time delay, the magnitude of which is inversely proportional to the signal magnitude. When the signal on the explosive element reaches the equal opening voltage the threshold element THR3 opens and passes a signal to the actuator of the power circuit KM that disconnects the engine from the network.

In case of short overload, the signal from THR1 to TD stops before its value reaches the voltage level at which the third threshold element THR3 opens and the motor does not turn off.

Functioning of the scheme in the phase failure control mode

The phase failure control of the electric motor is carried out by the primary converter PhFS, which uses the voltage system “motor zero - network zero” [24]. The circuit scheme functions similarly to the circuit scheme in the overload control mode with the only difference that the emergency mode signal arrives at the threshold element THR2 not from the CS current sensor, but from the PhFS phase failure sensor and further without using the time delay element (TD) to the actuator of the power circuit KM.

Figure 2 presents the electrical circuit of the given protection device. A comparator chip of the K554 CA3 type (operational amplifier) has been selected as the threshold element in the protection device. This element has a number of significant advantages compared with other analogues of threshold elements (for example, when used a dynistor analog or a threshold element based on a single junction transistor). A comparator is a microcircuit that implements the logical function of comparing two voltages applied to two inputs: direct and inverting.

Having a large gain, the microcircuit has a very high sensitivity, which ensures the operation of the microcircuit when the difference between voltage levels on both inputs is only a few dozens of millivolts. A standard DC power supply with a voltage of 5 to 12 volts can be used to power the comparator.

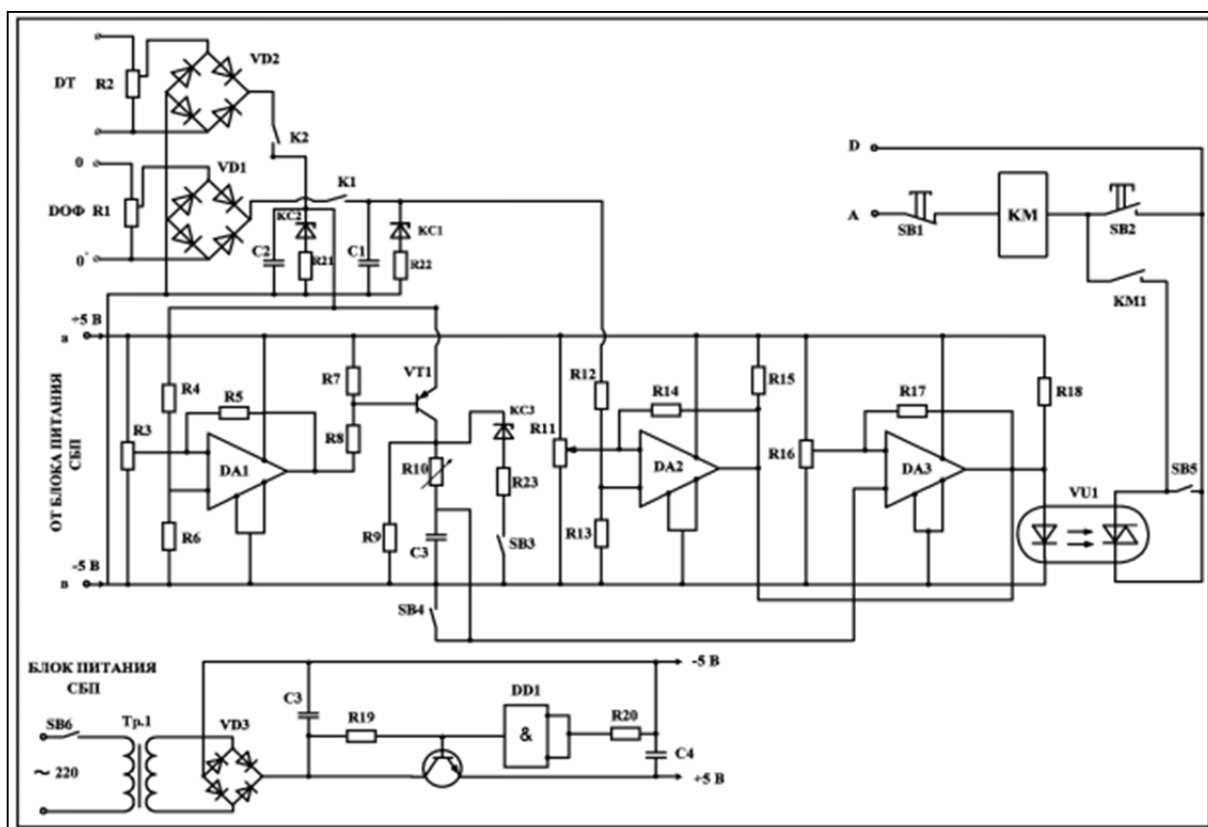

Figure 2. The electrical circuit scheme of the protection device.

Moreover, the comparator has significant speed, which allows it to work with any digital integrated circuits (in particular, the logic elements of the K155 series). A feedback resistor (FR) is a mandatory element of the comparator circuit in this case. The resistor is used to create a feedback circuit in order to obtain steeper rise and fall edges of input pulses. The comparator can be used according to the two functioning schemes.

In the first version the direct input No. 3 is supplied with a reference voltage U_{rv} , which determines the threshold of the comparator operation, which is regulated by a potentiometer Preg. The voltage of the input signal U_s is applied to the inverting input. This voltage is compared to the reference voltage U_{rv} at the input. If $U_s < U_{rv}$, then the comparator is locked and the voltage at its output is maximum at its output (that is, it is equal to the supply voltage). This case corresponds to the appearance of a logical unit at the comparator output. If $U_s \geq U_{rv}$, then the comparator is open and the voltage is minimal at its output (just a few millivolts). This case corresponds to the appearance of a logical zero at the comparator output. When the voltage of the signal $U_s < U_{rv}$ decreases, the comparator closes again.

In the second version, the reference voltage U_{rv} is applied to the inverting input and the voltage of the input signal U_s is applied to the direct input. In this case, the comparator works is inverse to its work in the first version.

Thus, the threshold element based on the comparator can implement the circuit operation, when the output of the threshold element can be either logical 0 or logical 1, which allows you to create different versions of the scheme.

A comparator-based threshold element provides communication with other logic elements (for example, microcircuits of the K155 series) without additional devices for matching, which greatly simplifies the circuit. Moreover, the input current of the comparator does not exceed $2 \mu\text{A}$. This is five thousand times lower than the input current of the threshold element constructed using a thyristor and a zener diode (such a circuit scheme is used in the protection device of the FUZ-M type). One should also take into account that the comparator has a significant temperature stabilization of the chip constituent elements. The threshold element circuit lacks such advantages, which is used on a single junction transistor in the protection device FUS-U.

Functioning of the protection device in the normal mode.

In the normal mode with a load of nominal currents, which flow through the power cable supplying the electric motor, a current flow through the primary winding of the CS current sensor (Fig.2), creating a voltage in the secondary CS winding, which is applied to the potentiometer R2, the rectifier bridge VD2 and the smoothing capacitor C2. Next, the rectified and smoothed voltage is applied to a voltage divider consisting of the resistances R4 and R6 and simultaneously to the transistor VT1. The potentiometer R2 on the direct input (No.3) of the comparator DA1 sets the voltage below the threshold value set on the inverse input (No.4) of the same comparator. Adjusting potentiometers R3, R11 and R16 previously set the reference (threshold) voltage applied to the inverse inputs (No.4) of the comparators DA1, DA2 and DA3. The magnitude of these voltages is specified in the table of protection device settings. Thus, a voltage lower than the voltage of the threshold value is applied to the inverting input DA1, which will be used in the direct input DA1. In this case DA1 is locked and the current flowing through its output (No. 9) and resistances R7 and R8 will be zero. No current in voltage dividers R7 and R8 results in the locked transistor VT1, since the firing voltage removed from R7 is also zero. When VT1 is locked, the voltage on the capacitor C3 is zero, since it is discharged through resistors R9 and R10. The voltage supplied from C3 to the direct input of the comparator DA3 equals zero too. In this case DA3 is locked and the current flowing through its output will be zero. When voltage is applied to the power supply of the protection device, resistor R18 and the LED of the

optocoupler VU1 will have enough current to open the photosimistor VU1. Open photosimistor VU1 closes the power supply circuit of the KM magnetic starter coil and the engine starts.

The protection device in the current overload mode.

In case of an overload, the voltage from primary converter DT through rectifier VD2 will be applied to the direct input of threshold element DA1. So, the applied voltage will be higher than the voltage of the threshold value applied to the inverting input of comparator DA1. In this situation DA1 is open and the current will flow through its output and resistances R7 and R8. If voltage appears on divider R4, R6 voltage will be above the breakdown of the voltage regulator diode KC2. The latter breaks through and the voltage is not higher than the value applied to the divider, which will protect the circuit from dangerous overvoltage. In case of current in voltage dividers R7 and R8, the firing voltage taken from R7, which is higher than required to open the transistor will be applied to the base of transistor VT1. When VT1 is unlocked through transistor and resistor R10 will flow the charge current of capacitor C3. When the capacitor reaches a voltage equal to or greater than the threshold voltage set at inverse input DA3, the latter opens and shunts the LED of opto-coupler VU1. In this case, the current through the LED will be equal to zero, the photosimistor will close and break the coil circuit of magnetic actuator MP. So, the engine is disconnected from the mains. When current overload reaches 50% or more, there appears a voltage on capacitor C3 that is higher than the breakdown voltage of the Zener diode KS3. The Zener diode breaks through and capacitor C3 will be charged additionally through resistance R22, which will significantly speed up the charging time and shorten the time delay.

Functioning of the protection device in the mode of the supply line phase failure.

In the rated load mode with rated currents, in case of a phase failure, an overvoltage from PhFS primary converter through VD1 rectifier will be applied to voltage divider R12, R 13. In this case, the voltage taken from R13 above the threshold value set on inverting input DA2 will be applied to the direct input of comparator DA2. DA2 comparator opens and the open output shunts the LED of optocoupler VU1. The current through the LED stops, photosimistor VU1 locks and breaks the coil circuit of the magnetic starter KM. In this case, the engine is disconnected from the mains. Disconnection of the engine will occur without time delay since such a mode is very dangerous and instantaneous disconnection of the engine from the mains supply is required. If a phase failure occurs on divider R12, R13, the voltage above 30.0 (V) appears, Zener diode KC1 breaks through and the voltage on the divider is not higher than this value, which will protect the circuit from dangerous overvoltage.

Conclusions

1. In the proposed circuit scheme of the protection device, there has been chosen the current method of monitoring the degree of motor load using the current sensor as the simplest and at the same time sufficiently effective. Taking into account the fact that the load of a three-phase asynchronous motor is the same for each phase of the motor, the control of the magnitude of the current overload can be carried out only in one phase, i.e. one current sensor.

2. The given protection device is universal, i.e. can be installed on any motor power from 0.55 kW to 11.0 kW. The device protects the engine directly from the three most likely emergency modes: overload (with inverse time delay), phase failure and rotor seizures.
3. The developed universal protection device UZU-1 is based on AS No. 1410175, AC No. 807435 and AC No. 877691. The device in its overall dimensions is made so that it can be installed inside the factory magnetic actuators instead of thermal relays. The device passed production tests and was introduced at a number of enterprises of the Republic of Moldova and the Russian Federation.

References

1. Mishin V.I. *Performance investigation of electric motors under the conditions of agriculture in Moldova*. Research Report. No. 868508 No. GR 800059075. MoldNIINTI. Chisinau: 1980, 55 p. [in Russian].
2. Nours D. *Transient Surges and Motor Protection*. IEEE. Transaction on Industry Applications, 2001, Vol. 1A-15, №6, p. 606-610.
3. United States, IPC HO2 H7 / 085. *Patent number 3932789*, IER 1976, № 09.
4. United States, IPC HO2 N7 / 08. *Patent number 4028736*, IER 1978, № 04.
5. Shapovalov K.A. *Protection of electric motors against thermal overload*. NTB on mechanization and electrification of livestock. Zaporozhye: 1977, issue 8, p.86-91. [in Russian].
6. Valobuev S.V. *Analysis of changes in the heating time constants of thermal relays* Mechanization and electrification of agriculture. 2015, №3, p.18-20. [in Russian]
7. Valobuev S.V. *Protection efficiency of asynchronous electric motors with thermal switches* . Mechanization and electrification of agriculture. 2012, № 6, p.24-25. [in Russian].
8. Zaitsev Yu.M., Ivanov, I.P., Nikolaev, N.N. *Investigation of the response time stability of devices based on thermo-bimetal elements*. Electrical Engineering. 2014, №4. [in Russian].
9. Musin A.M, Pankin V.V. *Application areas of thermal and built-in temperature protection*. Mechanization and electrification of agriculture. 1977, No. 5, p. 40-42. [in Russian].
10. Kostruba S.I. *Checking the alignment of electrical potentials at arable farms*. Engineering in agriculture. 1978, No. 2, p. 30-33. [in Russian].
11. Tubis Ya.B., Belov G.K. *Asynchronous motors with built-in temperature protection*. Mechanization and electrification of agriculture. 1973, No. 10, p. 28-30. [in Russian].
12. Tubis Ya.B., Belov G.K. *On the issue of asynchronous motors protection under the conditions of agricultural production*. Electrical Engineering. 1974, No. 12. [in Russian].
13. Tubis Ya.B., Belov G.K. *Temperature protection of asynchronous motors in agricultural production*. M: Energy, 1977. 104 p. [in Russian].
14. France, IPC HO2 N7 / 08. *Patent No. 2133279* , IER 1974, № 06.
15. Japan, IPC HO2 N7 / 085. *Patent №5138899*, IER 1977, № 04.
16. Ac I035717 (USSR). *Device to protect the drive from emergency mode*. Grundulis A.O., Schniders A.A. Publ. in BINO. 30, 1983. [in Russian].
17. Vodyanitsky Yu.G. *Improvement of protective shutdown devices*. Industrial energy. 2011, №8. [in Russian].
18. Kalinin A.F. *The choice of protection means of electric cars*. Mechanization and electrification of agriculture. 2014, №2. pp. 14-16. [in Russian].
19. Slobodkin A.Kh. *Improvement of technical means of protection in networks with voltage of 1000 V*. "Industrial energy. 2011, №1. [in Russian].
20. Somov I.Ya., Valobuev S.V. *Protection of asynchronous motors from non-normal operating modes*. Engineering in agriculture. 2012, №2, p. 20-21. [in Russian].
21. Shapovalov V.I. *Universal safety device*. Collection of scientific papers GAURM 46th edition, part 1. Chisinau: 2018 [in Russian].
22. Shapovalov VI, *Zero-sequence voltage as a diagnostic signal in electric motor protection devices*. Collection of scientific papers GAURM, Chisinau: 2000. [in Russian].