

## THE RE-EQUIPMENT OF TRACTOR ENGINES FOR DIESEL-GAS FUNCTIONING

O. Ene, V. Poroseatcovski  
Technical University of Moldova

### FOREWORD

Nowadays the natural, compressed gas is being used wider than ever [3]. Comparing it with other types of fuels it possesses many important advantages and one of most important and convincing is that natural, compressed gas is very ecological. The resulted exhaust gases, of engines operating on natural gas, represent a mixture of  $CO_2$  and water steams,  $NO_x$  emissions are lower with 65% and there is registered a quantity of 80% less solid micro-particles. The natural gas does not contain sulfur, it is not toxic and it is lighter than the air, finally it is 2-3 times cheaper than the gasoline. Therefore the re-equipment of the traditional engines for natural gas functioning represents a forthcoming challenge.

### 1. CONSTRUCTIVE ASPECTS OF THE RE-EQUIPMENT PROCEDURE

The re-equipment of ordinary diesel engines for diesel-gas operation can not be realized without the implementation of ingenious, engineering solutions and additional constructive applications because of the natural gas high ignition temperature needed to be achieved for self-ignition (680...750 °C) while diesel fuel inflames at 320...380 °C [2]. Therefore, in addition to natural gas, engine cylinders are supplied with a dose of diesel fuel, the "fire-dose". This dosage represents 20% of the mixture.

According to the obtained exploitation results the engines' diesel-gas functioning provides:

- power increase with 3...10%;
- reduced fuel consumption with 40...60%;
- reduced emissions;
- higher engine-oil resource.

All this and the growing market tendency of raising the prices for petrol products invoke the necessity of diesel engines re-equipment for diesel-gas functioning.

To achieve a reliable and stabile functioning of the re-equipped engines there must be calculated

the most important parameters of the gas mixer, which is additionally mounted on the engine.

The main purpose of the mixer results in the provisioning the cylinders with efficiently mixed air and gas.

Figure 1 represents the structure of a diesel-gas engine mixer.

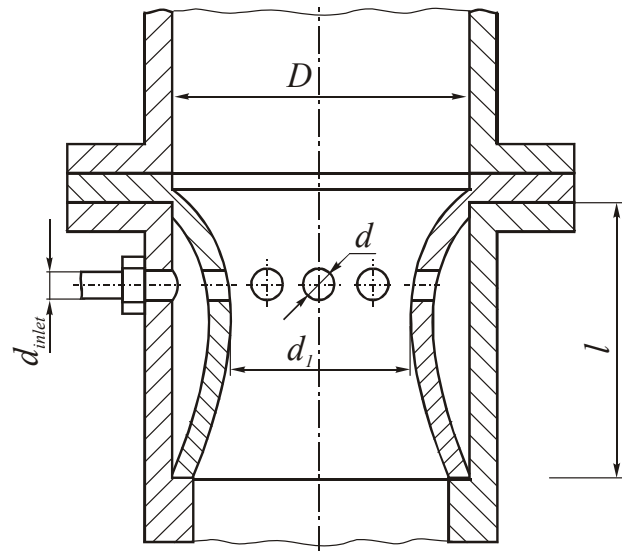

Figure 1. The structure of the gas mixer.

The air-gas correlation must be 7:1 to provide a good burning mixture. This may be done only possessing the correct dimensions of the inlet manifold  $D$  diameter, the diffuser's diameter  $d_1$  and its length  $l$ , the diameters of the gas channels  $d$  and the inlet port diameter  $d_{inlet}$ .

The diameter of the inlet manifold [1] may be determined by the formula:

$$D = (0,4...0,5)D_1 \quad (1)$$

where  $D_1$  – the cylinder diameter of the tested engine;

Usually it is used only one diffuser for multi-cylinder, low-power car engines.

The air capacity of the diffuser may be calculated by the following formula:

$$G_b = \mu_g \cdot f_g \sqrt{2\rho_k \cdot \Delta P_g} \quad (2)$$

where  $\mu_g$  - the diffuser's consumption coefficient;  
 $f_g$  - the area of the most narrow section;  
 $\rho_g$  - air density at the pressure  $P_k$  and temperature  $T_k$  when entering the diffuser.

According to relation (2) the diameter  $d_1$  may be determined as:

$$d_1 = 0,95 \cdot \sqrt{\frac{G_b}{\mu_g \sqrt{\rho_k \cdot \Delta P_g}}} \quad (3)$$

The diffuser's length may be established by the formula:

$$l = 2,1 \cdot d_1 \quad (4)$$

Considering the correlation of air and gas, for an optimal burning of the air-gas mixture, there may be written the equality of the consumption masses:

$$7\mu_g \cdot f_g \sqrt{2\rho_k \cdot \Delta P_g} = \mu_r \cdot f_r \sqrt{2\rho_r \cdot \Delta P_r} \quad (5)$$

where  $\Delta P_g$ ,  $\Delta P_r$  - depression, formed inside the diffuser, respectively for air and gas;

$\mu_r$  - the gas-jet coefficient;

$f_r$  - total area of the gas channels;

$\rho_r$  - gas density at the entering temperature.

To establish the total area of gas channels and to simplify the calculating process we shall consider

$$\mu_g = \mu_r \quad \text{and} \quad \Delta P_g = \Delta P_r :$$

$$f_r = 7 f_g \sqrt{\rho_k / \rho_r} \quad (6)$$

In correspondence with the number  $n$  of gas channels, there are determined apart the apertures diameters:

$$d = 2,986 \sqrt{\frac{f_g}{n} \sqrt{\rho_k / \rho_r}} \quad (7)$$

The mixture consumption ( $m^3/s$ ) may be established by the formula [1]:

$$V_{cm} = 0,03\eta_v \cdot V_h \cdot n_e \quad (8)$$

where  $V_h$  – the cylinder's volume,  $m^3$ ;

$\eta_v$  – cylinder filling coefficient;

$n_e$  – number of crankshaft rotations.

The mixture consumption, the speed of the gas jet and the area of the inlet port sectioning may be connected by one unique expression:

$$V_{cm} = 3600 \cdot f_{inlet} \cdot w_{inlet} \quad (9)$$

where  $f_{inlet}$  – area of the gas inlet port connected with the mixer,  $m^2$ ;

$w_{inlet}$  – the mixing speed inside the gas inlet port.

It is recommended to consider  $w_{inlet} = 20...30$   $m/s$ . The diameter of the gas inlet port may be determined by the expression:

$$d_{inlet} = 2\sqrt{V_{cm} / w_{inlet}} \quad (10)$$

Using the relations (1), (3), (4), (7) and (10), there may be established the main parameters of the gas inlet port used for diesel engines re-equipment for diesel-gas functioning.

### *References:*

1. *Е.Г. Григорьев, Б.Д. Колубаев, В.И. Ерохов, А.А. Зубарев. Газобаллонные автомобили. М. Машиностроение, 1989, 213 с.*
2. *А.С. Орлин и М.Г. Круглов. М. Двигатели внутреннего сгорания. Системы поршневых и комбинированных двигателей. Машиностроение, 1985, 436 с.*
3. *V. Poroseatcovski, O. Ene. The perspectives of diesel engines re-equipment for natural gas functioning. The VIII<sup>th</sup> International Conference of Motor vehicles, November, 16-17 2000 Pitești (Romania).*